

# Troubleshooting the Vertex D-Ring Tool

**Vertex Fasteners** is committed to providing our customers with world-class customer service and support. Our dedicated regional sales/service technicians are Vertex employees. They know the product, the business, and their customers, and are there to serve you. Vertex also has a well-trained staff of customer service, production and engineering professionals that are ready and able to assist you.

This and other manuals are available on our website: **WWW.VERTEXFASTENERS.COM**

## **MAINTENANCE**

Most problems with tools are a result of:

1. Normal wear and tear to components due to high usage.
2. Lack of proper lubrication.
3. Dirt or water that may enter the tool via air lines.
4. Defective rings.

## **LUBRICATION**

1. The **D-Ring tool** is designed for long, trouble free use with **minimal in-line lubrication**. (If an in-line lubricator is used, it should be set at a minimal rate of flow.)
2. When lubricating tool, **Pneumatic Fastening Tool Oil, VC0340** is recommended. When oiling, a couple of drops of oil should be placed through the airline fitting. Excess oil in tool will attract dirt, lint, and the tape used to collate rings, preventing smooth operation. Cycle tool to expel excess oil.
3. When servicing or repairing tool a **high grade lithium grease, Vertex part number VH0214** is recommended.

## **AIR FILTER AND REGULATOR**

1. The airline should always contain a filter and regulator unit to provide tool with a constant flow of clean, dry air. Moisture and contaminants entering tool will decrease the serviceable life of the tool.
2. The regulator should be set between **70 and 90 psi (4.8 to 6.2 bar)**. **Never operate tool over 100 psi (6.9 bar)**.

## **TIPS ON EXTENDING TOOL LIFE**

1. Always use **Vertex brand fasteners** and always use **Vertex genuine parts** when replacing worn or broken parts. **Generic fasteners, and parts** may shorten the tools life and **will void your tool warranty**.
2. Use tool at the minimum amount of air pressure needed to do work at hand. **Excess air pressure will reduce life of tool**.
3. Keep tool clean and dry and always use **clean dry air**.
4. Avoid dropping tool, a primary reason for parts replacement.

## HELPFUL HINTS FOR FIELD SERVICE TOOL JAMS

**SAFETY FIRST** – Always disconnect tool from air supply before attempting to clear a jam or servicing tool.

The most common reason for jamming problems is worn parts. Common parts that see a lot of wear are the jaws, pusher assembly and the pusher spring.

**Note:** refer to correct tool schematic for location of parts and correct part numbers.

### Common causes of jams:

- Worn or chipped jaws. Replace jaws



- Damaged pusher. Replace pusher
- Damaged pusher spring. Replace spring

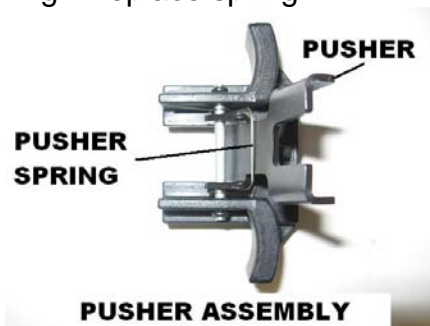

- Screw VH0026 missing. Replace screw (use Loctite 243)



- Defective fasteners. Return samples of rings to Vertex Fasteners representative for testing.

## RING DOES NOT CLOSE COMPLETELY

- Check air pressure. Line pressure should be between **70 and 90 psi (4.8 – 6.2 bar)**.
- A 3/8" (9.5 mm) or larger air line should be used. Air lines in excess of 100' (30 meters) can starve the tool of air preventing normal operation.
- Air leak in tool – refer to repair section of manual.
- Check for foreign debris in jaw area.
- The jaws may be worn from extended use. Check ring groove, if worn or chipped replacement is recommended.

### RING GROOVE



### LOOK FOR CHIPPING ALONG THIS EDGE

- Unlubricated and/or corroded parts may cause tool to function poorly. Light oil should be applied on a regular basis to surfaces of carriage, jaws, linkages and pins in corrosive or humid environments. Excessive amounts of oil will only attract dirt and foreign material which will hamper tool operation.
- Defective rings –
  1. Wire too hard
  2. Rough surface
  3. Cut-off burrs
  4. Wrong rings - Return samples of rings to your Vertex Fasteners representative for testing.

## FEEDING PROBLEMS

- If rings do not feed smoothly down magazine, check constant force spring for proper tension. There should be no kinks or bends in spring.



- Magazine should be free of dirt and other foreign matter.
- If rings feed freely down magazine but not into jaws, check jaws for freedom of movement and/or wear.

- Pusher latch worn, bent or broken. Replace latch.
- Latch spring broken or bent. Replace spring.

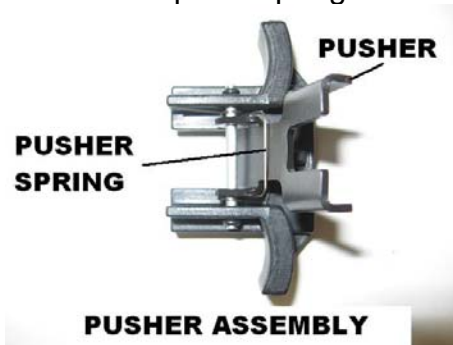

- Screw VH0026 missing. Replace screw (use Loctite 243)



- Defective rings
  1. Undersized (tight on magazine)
  2. Burrs
  3. Rings twisted
  4. Rings skewed on stick
  5. Rings out of line on stick
  6. Poor tape to ring adhesion
  7. Wrong rings - Return samples of rings to your Vertex Fasteners representative for testing.

### TOOL LEAKS AIR

If tool leaks air the most common cause is failed o-rings. Where the tool leaks air is important in determining the cause.

### Tool leaks from valve at rest

- Loose trigger. Tighten trigger using 7/16" wrench



- O-ring cut, cracked or twisted. Replace o-rings



#### **Tool leaks air when actuated operation weak**

- Piston o-ring damaged. Replace o-ring
- O-rings cut or cracked (valve area). Replace o-rings
- Trigger defective. Replace trigger

**Note:** some air may leak from trigger when actuated, this is normal. If leaking is excessive where it affects tool operation then trigger should be replaced.

#### **LACK OF POWER; SLOW TO CYCLE**

- Tool dry, lacks lubrication. Use Vertex air tool lubricant
- O-rings cut or cracked. Replace o-rings
- Dirt/tar build up on moving parts. Clean, lubricate with lithium grease.
- Check valve/trigger dirty. Clean, lubricate
- Competitors valve parts used. Use only genuine Vertex repair parts
- Broken return spring. Replace spring
- Air pressure too low. Check air supply