

PART #	DESCRIPTION	QTY
VC0048	HOSE	1
VC0225	ARM	1
VC0227	FRAME BASE	1
VC0246	PC5 CLIP SPOOL DISP. ASSY.	1
VC0255	STEEL PIN	1
VC0256	UPPER HALF OF UPRIGHT	1
VC0257	LOWER HALF OF UPRIGHT	1
VC0268	TRACK ASSEMBLY 'A'	1
VC0083	TRACK 'A'	1
VC0085	TRACK GUIDE 'A'	14
VH0042	SHCS, 8 - 32 x 1/4	28
VH0043	LOCK NUT, 8 - 32	28
VH0021	RETRACTABLE HOSE 3/8	1
VH0039	REGULATOR	1
VH0041	PRESSURE GAUGE	-
VH0042	SHCS, 8 - 32 x 1/4	2
VH0053	HHCS 1/2 - 13 x 3 1/4	4
VH0054	HEX NUT 1/2 - 13	4
VH0055	QCK DISCON. HOSE COUPLING	1
VH0056	NIPPLE 3/8 x 3	1
VH0057	ELBOW 3/8	2
VH0058	MALE CONN (COMP) 1/2 x 3/8	2
VH0060	SHCS, 5/16 - 18 x 3/4	2
VH0061	EYEBOLT 5/16 - 18 x 1 x 5/8	1
VH0062	HEX NUT 5/16 - 18	2
VH0064	TOOL BALANCER	1
VH0067	CAP	5
VH0071	COUPLING, 3/8 NPT	1
VH0098	SPRING SNAP, 5/16	1
VH0120	SPLIT LOCK WASTHER, 5/16	2

1. TO INCREASE TENSION, APPLY WRENCH TO FLATS ON SHAFT AND ROTATE COUNTERCLOCKWISE.
2. TO DECREASE TENSION, APPLY WRENCH TO FLATS ON SHAFT AND HOLD, SQUEEZE TOGETHER SPRING LEVER ON OTHER SIDE OF REEL, THEN ROTATE WRENCH CLOCKWISE.

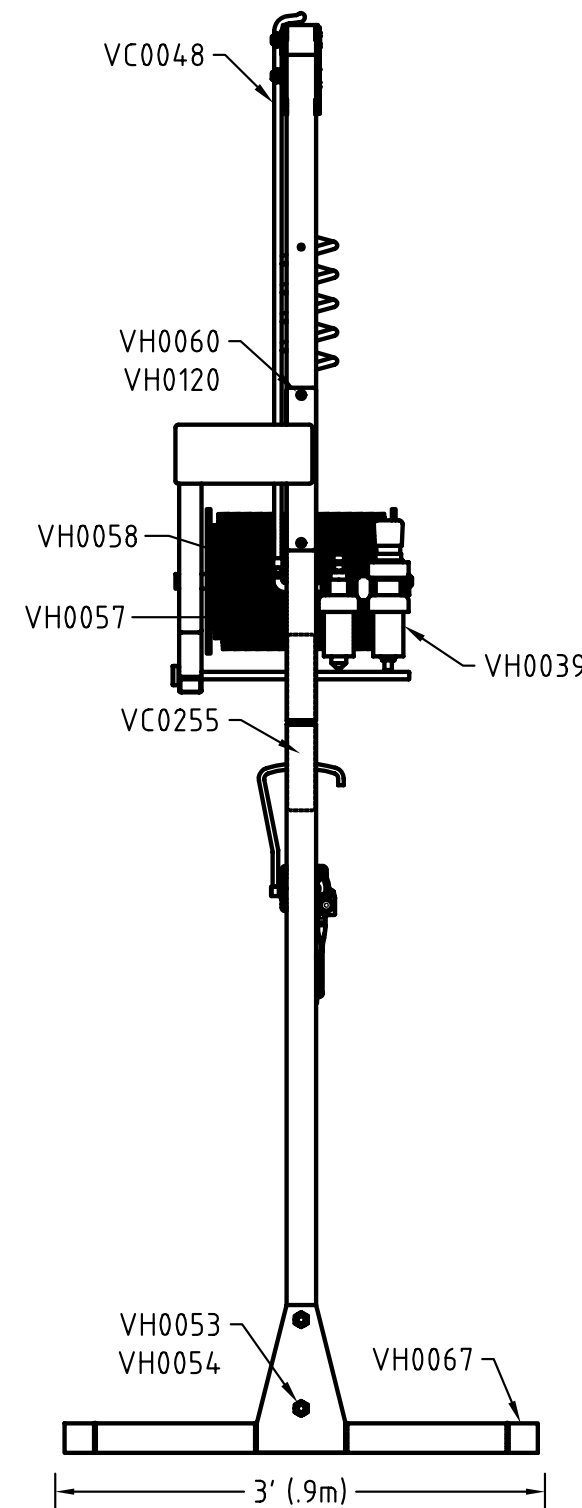
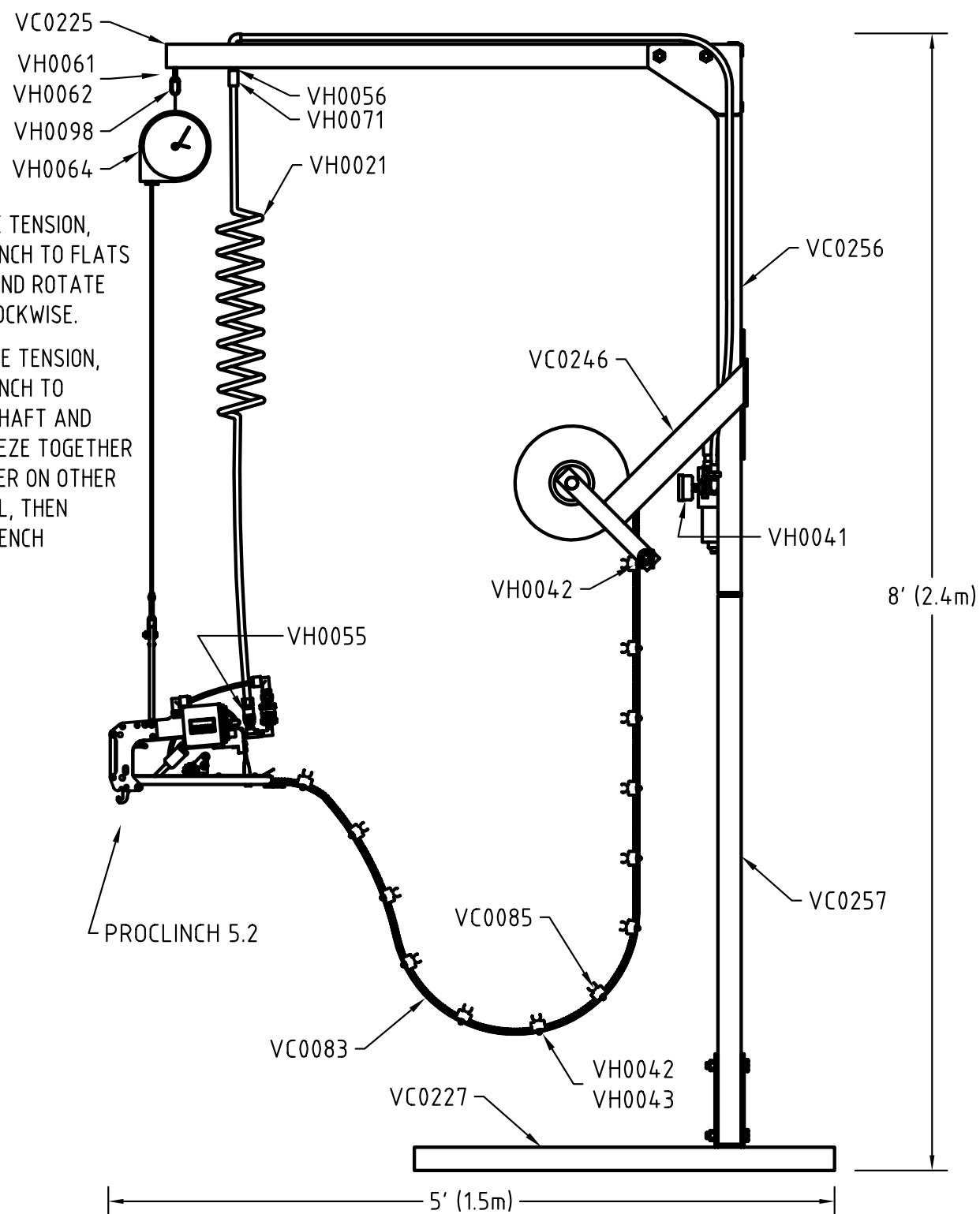

ProCLINCH 5.2 SYSTEM

REV	DESCRIPTION	BY	APPD	DATE	© 2000	VERTEX FASTENERS INC. 3714 JARVIS AVENUE SKOKIE, IL 60076 U.S.A. PROCLINCH FRAME ('A' CLIPS)
J	2000 FORMAT	JMW		7-17-00	DWN BY KH	
K	REMOVED EYEBOLT HOLES FOR TUBING	JMW		4-30-02	APPD	
L	ECN 657	JMW	DA	3-30-06	DATE 6-16-97	
M	ECN 727	JMW	DA	11-28-06	SCALE NONE	
					DWG. NO. VC2013/VA0189	B